

# CHIAYO

## Operation manual

### DWR-2420

Detachable Antenna Dual Channel  
Digital Receiver

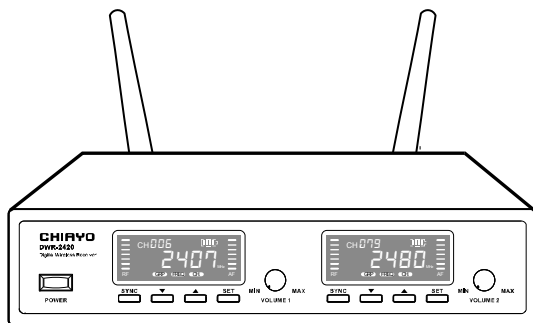

## DWR-2420 Detachable Antenna Dual Channel Digital Receiver

Thank you for choosing CHIAYO digital wireless microphone system!  
For more details, please take a few moments to read this operating manual for thorough understanding of the function and operation of both transmitter and receiver.

### In the box

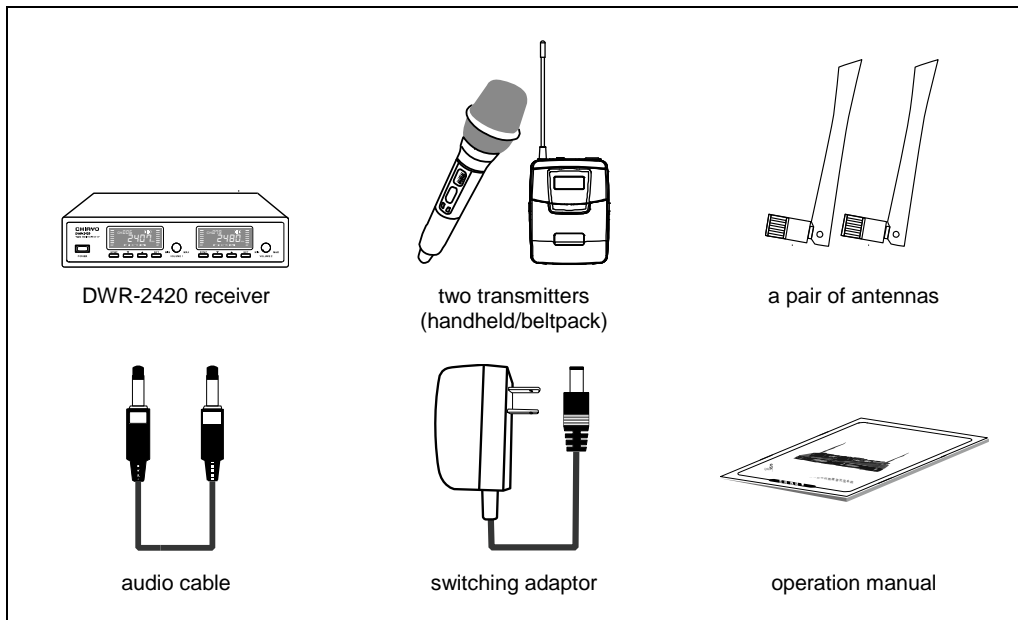

\*\* Remark: The above specifications are subject to change without prior notice.

### Parts and functions

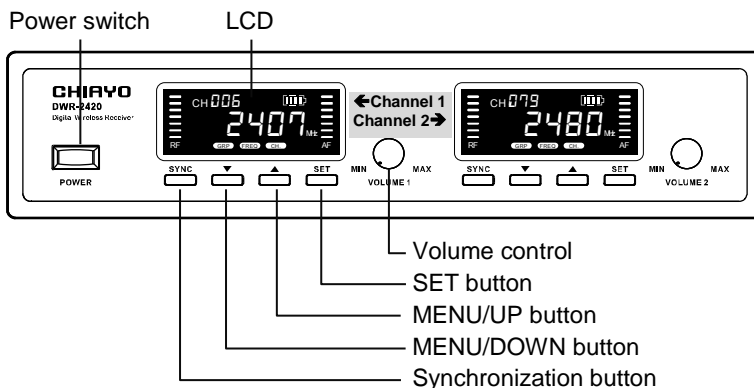

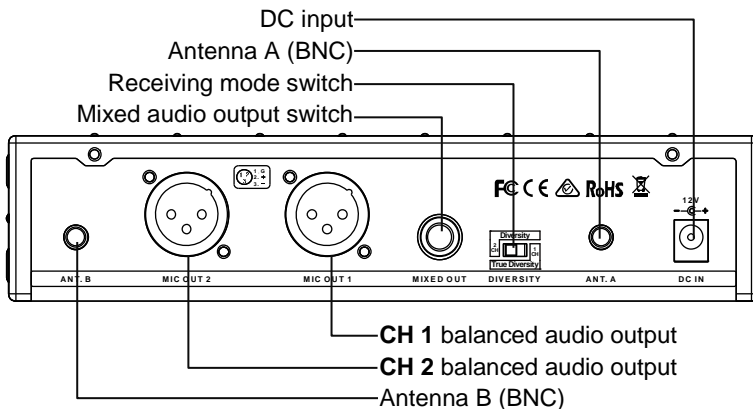

## Function settings on DWR-2420

### RECEIVING MODE setting

There are two receiving modes for selection.

- **2CH DIVERSITY:** For indoors like classroom and meeting room. Under this mode, you can use both transmitters and the reception is about 30m (line of sight).
- **1CH TRUE DIVERSITY:** For larger area. Under this mode, you can use only one transmitter but the reception can reach up to 100m (line of sight).

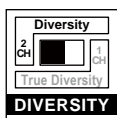
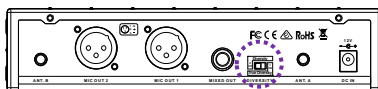

- Using two transmitters
- Diversity mode
- Distance about 30M (line of sight)

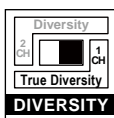

- Using one transmitter
- True diversity mode
- Distance up to 100M (line of sight)

## Changing CHANNEL / FREQUENCY

- 1** Press-release ▲ (UP) or ▼ (DOWN) button until the channel icon **CH** appears.

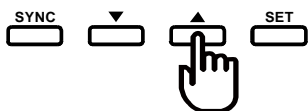

- 2** Press and hold **SET** button until the channel number flashes to denote readiness for setting.

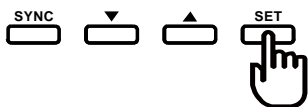

- 3** Press-release ▲ (UP) or ▼ (DOWN) button to select a new channel.

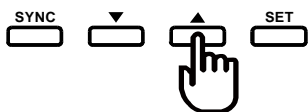

- 4** After a channel is chosen, press **SET** button to save the setting.

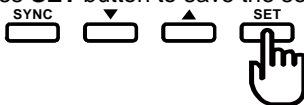

## CHANNEL scanning

For an interference-free operation, a cleaner channel might be necessary if the current one receives too much interference. Before scanning, the transmitter must be switched off. To operate the scanning:

- 1** Press-release ▲ (UP) or ▼ (DOWN) button until the LCD displays "SER000" and below frequency icon **FREQ** appears.

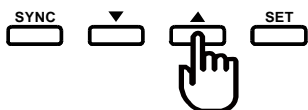

- 2** Press and hold **SET** button until "SER000" flashes to denote readiness for setting.

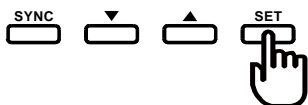

- 3** Press-release ▲ (UP) or ▼ (DOWN) button to find and locate a clear, interference-free channel.

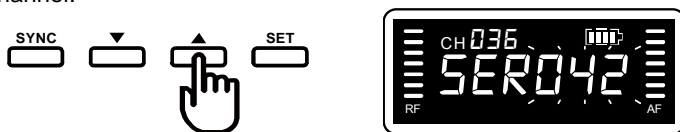

- 4** After a channel is chosen, press **SET** button to save the setting.

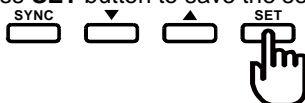

### CHANNEL SYNCHRONIZING of the receiver and transmitter

- 1** Press and hold the transmitter's synchronizing button until "LINK" flashes on the LCD.

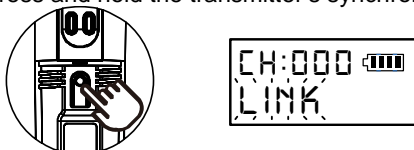

- 2** Press and hold the receiver's **SYNC** button until the frequency icon **FREQ** appears. After successful channel synchronizing, this icon will disappear automatically.

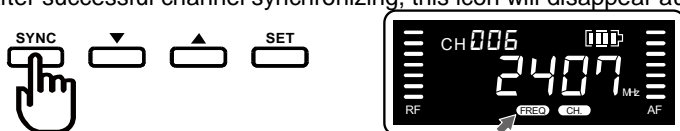

## CHANNEL GROUP setting

There are two channel groups for selection:

- GROUP **CH081** includes 81 selectable frequencies from CH1 to CH81.
- GROUP **CH189** includes 189 selectable frequencies from CH1 to CH189.

**1** Press-release ▲(UP) or ▼(DOWN) button until the below group icon **GRP** appears.



**2** Press and hold **SET** button until the group number and the icon **GRP** flash to denote readiness for setting.

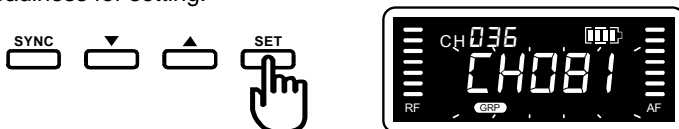

**3** Press-release ▲(UP) or ▼(DOWN) button to choose a channel group.



**4** After a group is chosen, press SET button to save the setting.

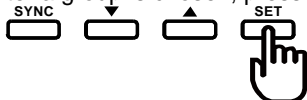

## Rack mounting

The receiver can be cabinet-mounted by either one or two units. If only one receiver is to be mounted, an optional kit is available and it's installed as shown in Fig 1. If two receivers are to be mounted, they can be assembled by another kit and installed as shown in Fig 2.

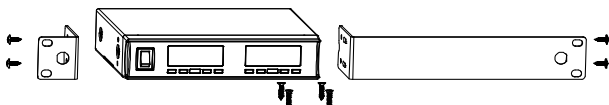

Fig 1: Rack mount of one receiver

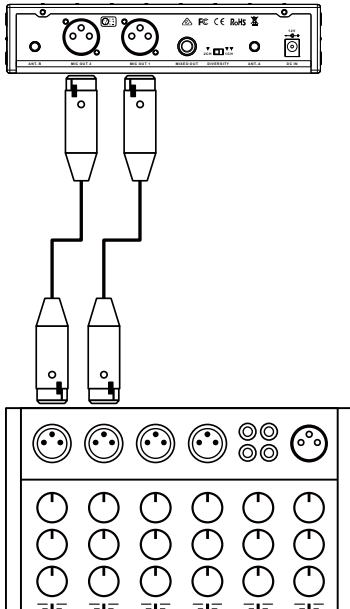

Fig 2: Rack mount of two receivers

## Audio output connection

- Balanced output:** XLR connector provides balanced audio output signal from this jack to the mixer/amplifier. Use an audio output cable with “XLR” or “Cannon” connector, connect one end to the balanced output jack of the receiver, and the other end to the “**MIC IN**” jack of the mixer/ amplifier.
- Unbalanced output:** ¼” PHONE PLUG connector provides unbalanced audio output signal from this jack to the mixer/amplifier. Use an audio output cable with ¼” PHONE PLUG connectors. Connect one end from the unbalanced output jack of the receiver, and the other end to the “**LINE IN**” jack of the mixer/ amplifier.
- Mixed audio output**  
 An unbalanced output socket generates mixed output of both channels. The unbalanced output socket (¼”) must connect to the unbalanced input socket.

MIC IN + Separate



LINE IN + Mixed

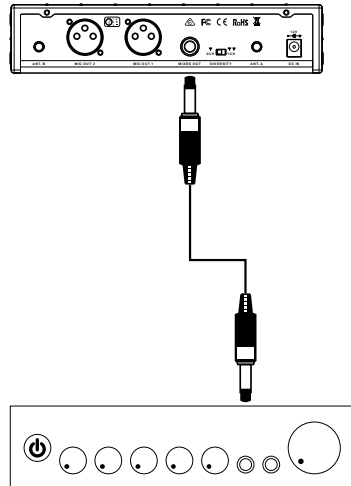

## Receiver installation

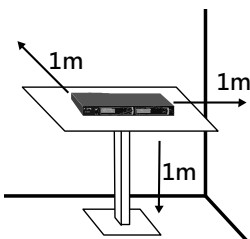

For best operation, the receiver should be at least 1m above the ground and 1m away from a wall or metal surface to minimize reflections. The transmitter should also be at least 1m away from a wall or metal surface to minimize reflections. The transmitter should also be at least 1m away from the receiver. Keep antennas away from noise source such as motors, automobiles, neon light as well as large metal objects.

**CHIAYO ELECTRONICS CO.,LTD.**

Http://www.chiayo.com.tw | Email: sales@chiayo.com.tw  
Office: 30, Lane 27, Section 4, Jen-Ai Road, Taipei 10685, Taiwan  
Tel: 886-2-27415741 | Fax: 886-2-27525242  
Factory: 88, Chung-Hsiao Street 2, Chiayi 60080, Taiwan  
Tel: 886-5-2711000 | Fax: 886-5-5767611

